

DÖRR

DAF-320

TTL FLASH

SONY MIS (MULTI INTERFACE)

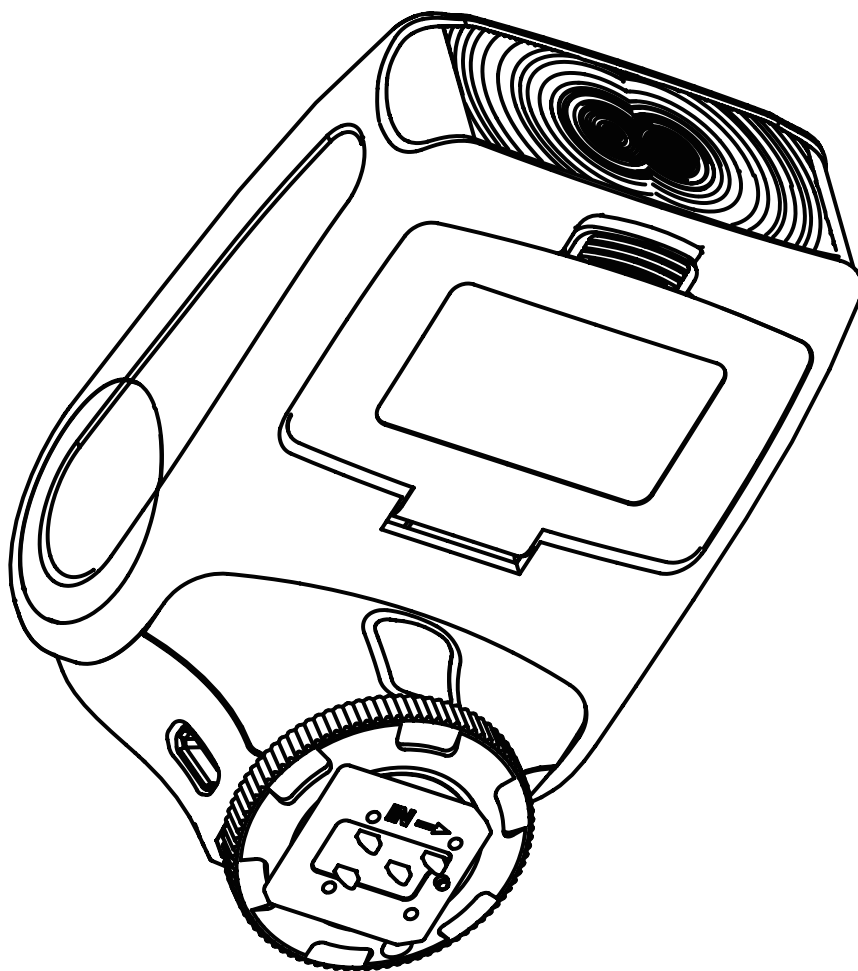

Thank you for choosing this DÖRR product.

Please read the instruction manual and safety hints carefully before first use. Keep this instruction manual together with the device.

SAFETY HINTS

- Do not use or touch the device kit with wet hands.
- If the device is not in use for a longer period, please remove the batteries.
- Protect the device from rain, moisture and extreme temperatures.
- Do not use the device if it has been dropped. In this case a qualified electrician should inspect the device before you use it again.
- If the device is damaged or if you notice a burnt smell: Interrupt the electronic power supply by removing the batteries. Do not attempt to repair the device by yourself. When service or repair is required, contact qualified service personnel.
- Never use aggressive cleansing agents or benzine to clean the device. We recommend a soft microfiber cloth to clean the outer parts of the device.
- Store the device in a dust-free, dry and cool place.
- Keep away from children.
- DÖRR is not liable for damages caused by improper use or the failure to observe the safety hints.

BATTERY HINTS

Only use high-quality batteries of popular brands. When inserting the batteries, please note correct polarity. Do not insert batteries of different types. Please remove batteries when device is not in use for a longer period. Do not charge the batteries - risk of explosion! In case of contact with battery acid rinse the affected area immediately with water and contact a doctor. Do not dispose of batteries in household waste.

INTRODUCTION

The DÖRR DAF-320 is a system flash, which harmonizes with the functions of your Sony DSLR or system camera. Our intension is that by using the DAF-320 you will achieve much better image results than with the use of the built-in camera flash or without flash. For an optimum use of the functions of your new flash unit, please read these instructions before starting to work with the flash.

KEY FEATURES OF THE DÖRR DAF-320

- **TTL Flash Control** – the required flash power is calculated and set automatically. Perfectly illuminated pictures are guaranteed.
- **+/- Correction** - for adaption to difficult light conditions
- **Powerful Flash** – guide no. 32; the flash ranges up to 15m (at ISO 400 and aperture setting F4.0)
- **Manuel Power Setting**– of great advantage for complex or creative picture composing
- **Flash Head can be bounced and tilted** – for indirect flash ensuring softer light characteristics
- **LED Modelling Light** – ensures precise autofocus even at low ambient light
- **Slave Mode** – for wireless and external use of the DAF-320 flash unit
- **Sleep Function** – auto power saving mode
- **Stable Flash Foot** – partly made of metal
- **Overheating Protection**
- **LCD** – displays all settings

NOMENCLATURE

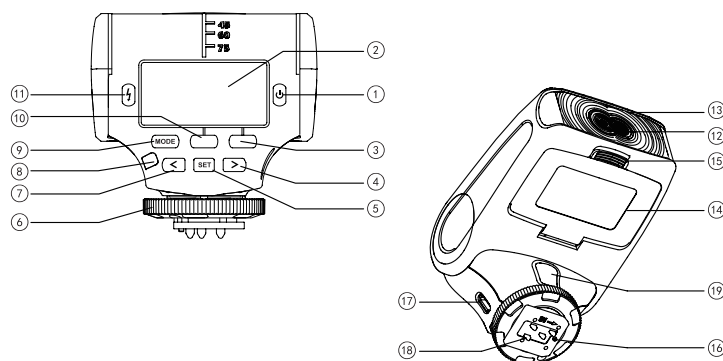

- | | |
|-----------------------------------------------------|---------------------------------------|
| 1 Main & Assist Light Switch | 12 Flash head |
| 2 LC display | 13 LED modelling light |
| 3 C2 | 14 Battery compartment |
| 4 Arrow key right | 15 Unlock key for battery compartment |
| 5 SET button | 16 Locking pin |
| 6 Clamp collar | 17 USB charging socket |
| 7 Arrow key left | 18 Flash contacts |
| 8 Flash ready indicator | 19 Wireless sensor |
| 9 MODE button | |
| 10 C1 button | |
| 11 Button for test flash and strobe modelling light | |

INSERTING THE BATTERIES

- Open the battery compartment by moving the unlock key forward.
- Insert 2 Mignon AA batteries into the battery compartment and make sure to respect the polarization as indicated in the battery compartment.
- Close the compartment lid by pressing until it clicks closed.
- Press the main switch for 2 seconds to switch the flash unit on.

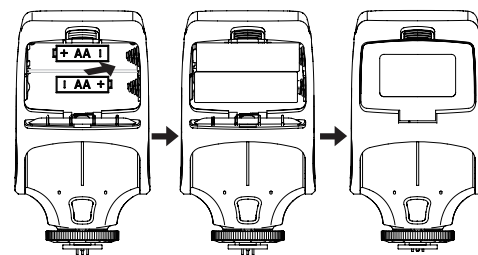

BATTERY STATUS DISPLAY

When switching on the flash, the LCD shows a battery symbol, indicating the battery capacity. In case the batteries are exhausted, an empty battery symbol will blink. If so, please replace the batteries with fresh ones or recharge the batteries (if using rechargeable ones).

CHARGING BATTERIES

We recommend the use of rechargeable NiMH or Li-Ion batteries for ecological and economic reasons. The batteries can remain in the flash's battery compartment during the charging. Connect the flash via Micro USB cable to a power bank (both optional) or another power source of AC 5V 1A.

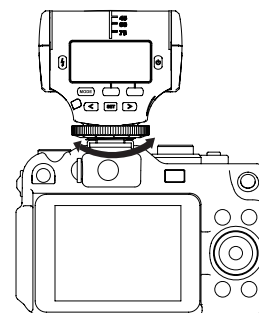

MOUNT THE FLASH ON YOUR CAMERA AND SWITCH THE FLASH ON

- Slide the flash onto the camera's hot shoe as far as it will go.
- Fix the clamp collar by rotating it clockwise. So the flash will not get loose accidentally.
- If you wish to remove the flash from the camera, rotate the clamp collar counter clockwise.
- Press the main switch for 2 seconds to switch the flash unit on.

SLEEP MODE

In order to save the battery power, the DAF-320 flash is fitted with a power saving function. It becomes active 60s after last use of the camera, or when you switch the camera off. The flash goes to standby mode and the display shows Sleep. When you switch camera on again, the flash will automatically be ready.

OPERATION OF FLASH

TTL FLASH CONTROL WITH PROGRAM MODE

Once the flash is mounted on the camera, switch the camera on and set it to program (P) mode. Aperture and flash sync time will be set automatically. Now switch the flash unit on. In case the flash is not in TTL mode, press the MODE button repeatedly until the TTL flash mode is on. The LCD shows "TTL". When the flash ready signal indicator on the flash starts glowing, you simply need to press the release button of your camera. The auto TTL flash control ensures exact illumination of your object by controlling both the camera's and the flashgun's amount of light.

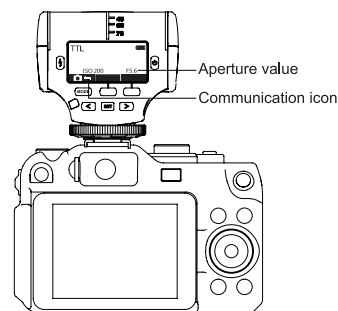

TTL FLASH CONTROL WITH APERTURE PRIORITY MODE

If you wish to take pictures in aperture priority mode in favour of a certain focus range, the TTL flash control will be available as well. Set your camera to aperture priority mode (A/Av) and the flash to TTL mode. Now you can set the desired aperture at the camera manually. Please note that the flash range decreases with smaller apertures (higher aperture numbers).



TTL FLASH CONTROL WITH SHUTTER PRIORITY MODE

Set the camera to shutter priority mode (S/Tv) and the flash to TTL mode. Now you can set a desired exposure time on your camera. However, it should not go below the camera's shortest flash sync time (x-synchronization) – see camera manual.

TTL FLASH CONTROL WITH MANUAL EXPOSURE SETTING

Set your camera to manual exposure mode (M) and the flash to TTL mode. Now you can set the aperture and exposure time as desired. Despite of the manual setting, the TTL flash control will automatically provide the correct illumination for your object.

MANUAL FLASH EXPOSURE COMPENSATION WITH TTL CONTROL (+/- CORRECTION)

The auto TTL flash control usually ensures correct illumination. Some objects require a more natural image effect, so the flash power needs to be slightly reduced. In other cases, a slightly increased flash power can improve the image result. Press the SET button to set the desired exposure compensation value. The display shows 0.0EV. Pressing the right arrow key, you can increase the flash power, using the left arrow key, the flash power will be reduced. Each step corresponds to approx. 1/3EV. 1 EV corresponds to 1 aperture step. Once the desired correction figure is selected, confirm by pressing the SET button again. The correction value will be used until changed. The auto TTL flash control remains active; however, the flash power will be influenced by the set correction value within a range of -3.0EV to + 0.3EV.

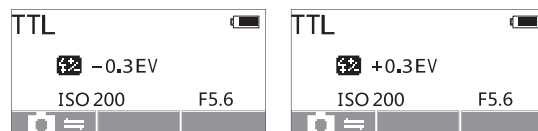

MANUAL FLASH MODE PHOTOGRAPHY

For manual flash mode, press the MODE button until the LCD shows “M” followed by the flash power ratio. The full flash power ratio 1/1 can be reduced down to 1/128. To set the desired flash power, press the SET button. The flash power shows up in the LCD with a dark background and can be varied in 1/3 EV steps by pressing the arrow keys. Aperture must be set manually. The flash range varies according to the aperture in use.

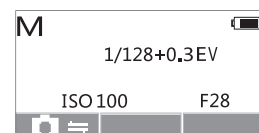

FLASH RECYCLING TIME DISPLAY

Depending on the flash power output, it may take up to 5 seconds until the flash is ready for the next shot. During the charging time, the flash ready indicator blinks. Once it glows permanently, the flash unit is ready to fire the next flash.

INDIRECT FLASH

The DAF-320 boasts of a bounce and tilt flash head. So the flash direction can be changed horizontally by 150° (60° to the left, 90° to the right) and from -7° to 90° vertically.

You can avoid the direct flash onto your object, by directing the flash to a reflecting surface (incident angle = angle of reflection). The surface should be neutrally white (white wall or ceiling). When using coloured reflection surfaces, the colour of the surface will be reflected with the light, this will lead to colour distortions.

Indirect flash photography offers you the following advantages:

- avoids harsh shadows
- avoids red-eye effect
- soft outlines and even illumination (particularly suitable for portraits)
- avoids disturbing light reflections of non-metallic surfaces, e.g. glasses

Please consider that indirect flash photography reduces the flash range.

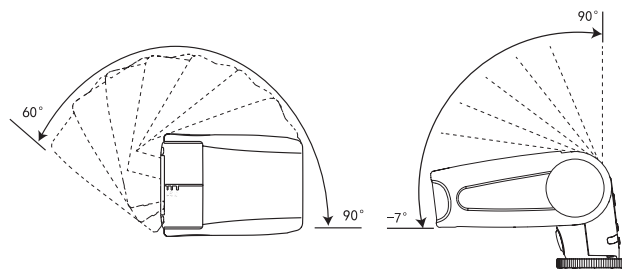

FLASH WITH DIFFUSOR

Portraits require a softer illumination. Instead of indirect flash, you can use the supplied diffuser. Mount it to the flash head front, then tilt the flash head upwards. The flash range will be reduced with the use of the diffuser.

WIRELESS TTL FLASH (OFF CAMERA)

SLAVE FUNCTION S1

You can initiate the DAF-320 wireless flash by a master flash (incorporated camera flash or another flash unit without pre-flash). Press the MODE button of D-320 until S1 appears on the LCD. The slave photocell is activated now and the corresponding symbol is shown on the LCD. Your camera must be set to C (commander flash) at the flash menu. Place the DAF-320 flash at the desired position. The light sensitive photocell will now receive reflecting light from the incorporated flash or another flash unit and releases the DAF-320 flash to fire simultaneously. In case the picture results achieved in S1 mode are not satisfactory, please try to work with mode S2.

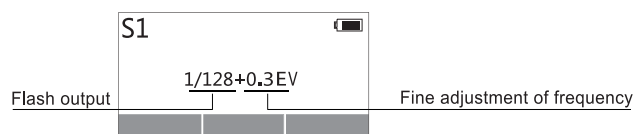

SLAVE FUNCTION S2

Modern TTL flashes fire one or more pre-flashes shortly before the main flash is fired. In order to release the DAF-320 flash in slave mode simultaneously with the main flash, the photocell must ignore the pre-flashes. For this purpose, use the S2 mode. Press the MODE button until S2 appears on the LCD. The S2 function is identical to S1 slave function, except that the pre-flashes will be ignored. In case the picture results achieved in S2 mode are not satisfactory, please try to work with mode S1.

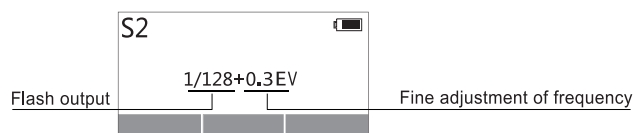

FLASH POWER IN SLAVE MODES S1 AND S2

TTL flash control is not active in slave mode. When using the slave function, select the desired flash power. First, press the SET button. The flash power shows up in the LCD with a dark background and can be varied in 1/3 EV steps by pressing the arrow keys.

1 EV step corresponds to 1 aperture step). Both aperture and exposure time need to be selected manually on the camera. Depending on the aperture, the flash range may vary. Note: The slave sensor is located at the front of the flash. In slave mode, the flash and the sensor should be directed towards the master flash. In slave mode, the Sleep power saving function is not available.

FLASH WITH MULTI STROBE LIGHT

Depending on the object, it can be charming to flash repeatedly while using bulb mode. This how you can, for example, you can show the course of motion of a tennis player. Press the MODE button until MULTI shows up in the display. Now you can set the 3 parameters:

- Flash power:** First, press the SET button to adjust the flash power. The flash ratios start blinking in the LCD. Using the arrow keys, you can adjust the flash power in full EV steps from 1/128 to 1/8 of the full flash power. (1 EV step corresponds to one f-stop).
- Number of Flashes:** Press the C1 TIME button until the flash frequency starts blinking in the LCD. Here you define the number of flashes fired during one picture shot. Using the arrow keys, you can select from 1 to 10 in steps of 1 and from 12 to 70 in steps of 2. Confirm the setting by pressing the SET button again. .
- Frequency of the fired flashes:** In order to define the time interval between the flashes, press the C2 Hz button. Use the arrow keys to select a flash frequency between 1 and 10 in steps of 1 or from 10 to 100 in steps of 10. Confirm the setting by pressing the SET button again. 1Hz corresponds to 1 second, 10 Hz = 1/10s, etc.

Example for calculation of exposure time: You would like to fire the flash 20x during an exposure with 1/32 power ratio and a frequency of 10Hz. 20x 1/10s = 2s exposure time. Given by the higher energy consumption using strobe flash, not all flash frequencies and flash power ratios can be combined. The following settings are possible:

	1 Hz	2 Hz	3 Hz	4 Hz	5 Hz	6 Hz	7 Hz	8 Hz	9 Hz	10 Hz	20 Hz	30 Hz	40 Hz	50 Hz	60 Hz	70 Hz	80 Hz	90 Hz	100 Hz
1/8	14	14	12	10	8	6	6	5	5	4	4	4	4	4	4	4	4	4	4
1/16	30	30	30	20	20	20	20	10	10	8	8	8	8	8	8	8	8	8	8
1/32	60	60	60	50	40	32	28	24	22	20	12	12	12	12	12	12	12	12	12
1/64	90	90	90	80	70	56	44	36	24	24	24	24	24	24	24	24	24	24	24
1/128	90	90	90	80	70	56	44	36	24	24	24	24	24	24	24	24	24	24	24

LED ASSIST LIGHT FOR AUTOFOCUS

The DAF-320 flash is fitted with an autofocus assist LED light. In case of very low light, the contrasts of your object may be insufficient for proper autofocus. In this case, the autofocus assist LED will go on, when the camera shutter is pressed halfway down. So the object will be illuminated and even in the darkest rooms, the autofocus will be able to work fast and precisely. Some cameras and certain settings will not support this function. Then the LED assist light can be switched on by pressing the Main/Assist Light button once. By pressing it again, you can switch the LED assist light off.

STROBE ASSIST LIGHT

Press the flash button for 2 seconds. The strobe assist light will work for approx. 2 seconds.

OVERHEATING PROTECTION

The DAF-320 is fitted with an overheating protection. In case of permanent and highly frequent flash firing with minimum 1/4 flash power, the DAF-320 is protected against damages caused by overheating. The flash will go off for approximate 2 minutes and a cooling mode starts. The LCD shows TP-HI.

SPECIFICATIONS

Flash Control	TTL auto flash for Sony MIS or manual
Guide no.	32 / ISO 100
Information	Illuminated LC Display
Tilt Angle	-7° to 90°
Bounce Angle	150° (60° left, 90° right)
Flash Ready Indicator	red LED on the rear side of flash housing
AF Assist Light	LED light
Flash Recycling Time	max. 5s with fresh batteries
Number of Flashes	100 – 1500 with fresh batteries
Colour Temperature	approx. 5.500 K
ISO No	automatic match with camera
Test Flash	by pressing the flash button
Slave Function	incorporated photocell for 2 slave modes
Energy Source	2x 1,5V AA Mignon batteries or rechargeable batteries of the same type
USB Micro/Mini 5pin Socket	for battery charging (cable not included)
Weight	approx. 150g (w/o batteries)
Measurements	110 x 65 x 35 mm
Items in box	Flash, diffusor, case, stand, manual

Power Ratio Setting	1/1	1/2	1/4	1/8	1/16	1/32	1/64	1/128
Guide No.	32	29,4	21,5	15,2	10,8	7,6	5,4	5,1

Based on ISO 100, guide no. = aperture x distance in m

**ATTENTION**

Batteries are marked with the symbol of a crossed out bin. This symbol indicates that empty batteries or rechargeable batteries which can no longer be charged, should not be disposed of with household waste. Waste batteries may contain harmful substances that can cause damage to health and to the environment. Please use the return and collection systems available in your country for the disposal of the waste batteries.

**WEEE INFORMATION**

The Waste Electrical and Electronic Equipment Directive (WEEE Directive) is the European community directive on waste electrical and electronic equipment, which became European law in February 2003. The main purpose of this directive is to prevent electronic waste. Recycling and other forms of waste recovery should be encouraged to reduce waste. The symbol (trash can) on the product and on the packing means that used electrical and electronic products should not be disposed of with general household waste. It is your responsibility to dispose of all your electronic or electrical waste at designated collection points. Disposing of this product correctly will help to save valuable resources and it is a significant contribution to protect our environment as well as human health. For more information about the correct disposal of electrical and electronic equipment, recycling and collection points please contact your local authorities, waste management companies, your retailer or the manufacturer of this device.

RoHS CONFORMITY

This product is compliant with the European directive 2011/65/EU of June 08, 2011 for the restriction of use of certain hazardous substances in electrical and electronic equipment (RoHS) and its amendments.

**CE MARKING**

The CE marking complies with the European directives.